

6699A Pump Station:

- > .5 HP motor – 120 Volts – 7.4 Amps, 60hz, 1725rpm.***
- > .5 gpm pump @ 1725rpm***
- > Motor/pump combination supports 18 nozzles.***
- > Dual filtration 5 & 10 micron filter housing uses standard garden hose water connection for easy hook up.***

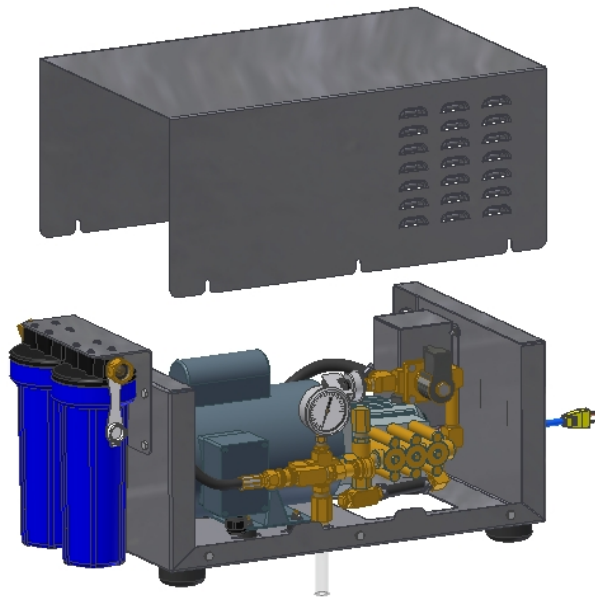



READ AND SAVE THESE INSTRUCTIONS

Initial Set-Up of Unit:

- 1) Remove the pump unit from the shipping carton.
 - a) Mount the pump unit on the floor or on a sturdy shelf in a central location to the desired misting fans.
 - b) **Be sure to use the attached tubing supports, and tighten the compression nuts all the way.**
 - c) A suggested strategy would be to place a high pressure “Ball Valve” or “Plug Valve” in the branch water line of each fan. Otherwise, all the fans must be running when the pump is “ON.”
- 2) Note: Before connecting the source water line to the pump, purge all air from the line. The source water line must be capable of delivering at least 1/2 gallon of water per minute for each fan at a pressure not less than 25 Psig and not more than 125 Psig.
- 3) **Important: The water source must be free of pressure surges caused by other equipment. Pressure surges may cause air to become entrained in the water supply. Running the pump under a pressurized but dry condition will void the warranty on the pump assembly.**
- 4) Plug the pump unit power cable into a 15-amp “dedicated” power outlet of the appropriate voltage for your unit.
- 5) Initial system start-up procedure:
 - a) Start all the fans first.
 - b) Start the pump unit and set the discharge pressure for 500 Psig.
 - c) Inspect the entire system for water leaks.
 - d) Stop the pump unit and fix each water leak point if necessary.
 - e) Adjust discharge pressure to desired setting.

Operation of Unit:

- 1) Turn on the pump unit source water. **The pump will not run without a pressurized line.**
- 2) Turn the pump unit “ON” to produce the “flash-cooling” effect.

Maintenance:

DISCONNECT ALL ELECTRICAL POWER AND THE SOURCE WATER HOSE PRIOR TO PERFORMING ANY MAINTENANCE.

- 1) PUMP UNIT:
 - a) The water pump oil should be replaced after the first 50 hours of operational time.
 - b) Subsequent oil changes should occur after every 3 months or 500 hours of operational time, whichever comes first. Use special CAT pump oil, 10.oz per change. J.E. ADAMS Industries, Ltd. Pn 6611B013. Do not fill above the center of the oil viewing glass.



Storage Procedure:

If your system is an “indoor” application, the equipment may left in place and drained of water when not in use for extended periods of time.

- 1) If your system is an “outdoor” application, disconnect the pump unit electrical power.
- 2) Disconnect the water hose from the unit inlet fitting.
- 3) Remove one or two nozzles at the top of each nozzle ring to drain the high pressure water line.
- 4) Install the winterization adapter, J.E. Adams Pn 6687T001, on the water hose inlet fitting at the pump unit.
- 5) Connect a compressed air source to the winterization adapter
- 6) Run the pump unit to clear water from the system. The system will be clear after the pump has run for a few seconds. **DO NOT LEAVE THE PUMP UNATTENDED** during this operation. If the pump unit is run with air more than a few seconds, it will become permanently damaged.
- 7) Remove the compressed air source and the winterization adapter.
- 8) Remove the particulate filter bowl and replace the water filter element.
- 9) Re-assemble the filter and replace the pump unit cover.
- 10) Plug all water fitting openings and protect the nozzle fittings from damage.
- 11) Wipe down the pump unit to remove excess water droplets.
- 12) When starting up the next cooling season, perform the necessary steps listed in the “Initial Setup of the Unit” section.
- 13) Once this has been done, the system may be operated normally.

Troubleshooting:

Problem	Solution
The unit fails to operate	Verify that the unit is plugged in and that electrical power is available. Verify that the source water hose is connected and that water flow is adequate. The source water pressure should be between 25 and 70 Psig. The flow capacity at the unit should be between 1/3 and 1/2 gallon per minute per fan.
The unit fails to produce mist.	Verify that the source water hose is connected and that inlet valve and the hose bib are both open and that water flow is adequate. The source water pressure should be between 25 and 125 Psig. The flow capacity at the unit should be at least 1/2 gallon per minute per fan head.
One or more nozzles fail to produce mist while others do.	The nozzles not producing mist may be plugged and should be cleaned or replaced. CAUTION! – clogged nozzles will cause the pump to run excessively hot and could damage the unit! The Water Conditioner cartridge needs to be replaced.
The motor/pump runs poorly or hot.	Check the electrical power available at the unit. 120 Volt units will operate correctly with electrical voltage readings from 108 Volts to 132 Volts AC.

<p>The pump stops running and periodically restarts.</p>	<p>The thermal overload device is doing its job, (protecting the motor from overheating). This will be likely to happen to a pump motor if the discharge pressure has been set too high. Set the pressure regulator to 1,000 Psig maximum. In any event, do not exceed the FLA (Full Load Amps) listed on the motor nameplate. Use an ammeter to verify the setting.</p> <p>The pump motor will run intermittently when either or both the filter and water conditioner must be replaced. When the filter or water conditioner become plugged due to sediment accumulation, the pressure switch will stop the pump motor. When the pressure builds up again, the pump will run for a short period of time. Replace the water conditioner and the filter cartridge.</p> <p>If this becomes a common occurrence, the motor may have developed a problem requiring replacement.</p>
<p>The pumping unit leaks water from the cabinet.</p>	<p>Disconnect the unit electrical power. Remove the cover and repair leaks as required. The thermal relief valve may be operating to keep the pump from overheating. Do not plug or otherwise disable the thermal relief valve.</p>

For other problems please contact your dealer, or J.E. ADAMS Industries at (800) 553-8861

6699A

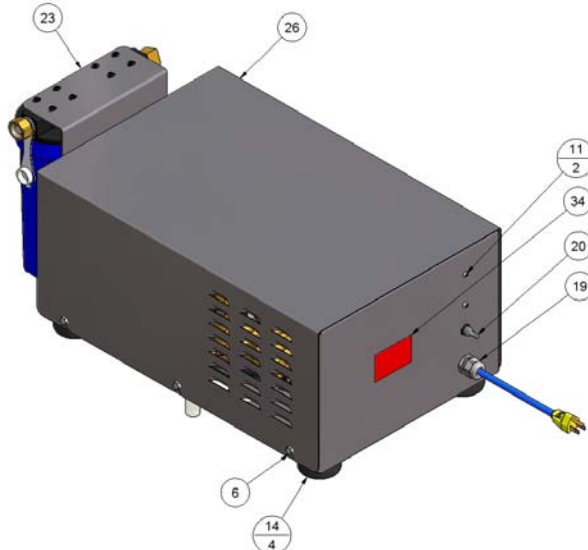

BILL OF MATERIALS			
ITEM	PART NUMBER	DESCRIPTION	QTY
1	3010_20.5 in.	HOSE, MEDIUM PRESSURE, 3/8 IN.	1
2	3010_7.5 in.	HOSE, MEDIUM PRESSURE, 3/8 IN.	1
3	3059	3/8 HOSE BARB X 3/8 NPT	2
4	3113	TUBING, CLEAR PVC, 5/8 IN. I.D.	10 ft.
5	3121B025	HOSE, PULSE, PUMP STATION	1
6	5601D4	1/4-20 x 3/4 HHCS-SS	10
7	5603D3	3/8 Std NC Nylock Nut	4
8	5606D2	1/4 WASHER	8
9	5606D8	WASHER	4
10	5622D1	3/8-16 UNC x 1 CAP SCREW	4
11	5636D1	#10-24 PHIL. PAN HEAD SCREW	2
12	5639D11	ISOLATION MNT, 50 DUR NAT RUB 1/4-20	4
13	5643D2	SS HOSE CLAMP, 7/16-25/32"	5
14	5655D1	RUBBER BUMPER, RECESSED MOUNT	4
15	5800D2	3/8 STR ELBOW, 90 DEG. BRASS	1
16	5814D4	PIPE BUSHING	1
17	5907D1	1/2 CONDUIT LOCKNUT	1
18	5915	SWITCH, DPST, 20A, 11/2 HP	1
19	5918D2	STRAIN RELIEF FITTING	1
20	5920	BOOT, TOGGLE SWITCH	1
21	5971D1	POWER CORD, 14AWG/3 x 25FT, 125V	1
22	5991B001	DIN CABLE, 3/18GA 90 DEG, GREY PVC	1
23	6699-10A	DUAL FILTER ASSEMBLY, 10 IN.	1
24	6699-1A	PUMP ASSEMBLY, 0.5 GPM, 0.5HP	1
25	6699-1W	WELDMENT, PUMP BASE	1
26	6699-2	COVER, ECONO PUMP STATION, 18ga	1
29	7214P	1/4 FEMALE SOCKET ASSEMBLY	1
30	7648	BULKHEAD NUT	2
31	7659	BULKHEAD CONNECTOR - 3/8NPT	2
32	8036	NUT, 1/4-20 UNC KEPS	12
34	8182	DECAL, "DISCONNECT POWER"	1
36	6699-9-1	SWITCH COVER, AQ BR	1
37	5603D1	10 Std NC Nylock Nut	2

C	5036	CHANGE ISOLATOR BUSHING FROM 5639D9	032609	JF
B	4988	REMOVE SWITCH CVR. 6699-8W, 6699-9, 8157, ADD ITEMS AS LISTED	2-09	JF
REV	NO.	DESCRIPTION	DATE	BY

THIS DOCUMENT SHALL NOT BE REPRODUCED NOR SHALL THE INFORMATION THEREIN BE USED BY OR DISCLOSED TO OTHERS EXCEPT AS AUTHORIZED BY J.E. ADAMS INDUSTRIES

1" PUMP STATION, MULTI-FAN, 0.5 gpm	
UNSPECIFIED TOLERANCES 1 PL. ±.030 2 PL. ±.020 3 PL. ±.010 ANGLE ±1.0°	MATERIAL SCALE DRAWN BY RICK FILOSA DATE 3/23/2007
PART NO. 6699A	REV C

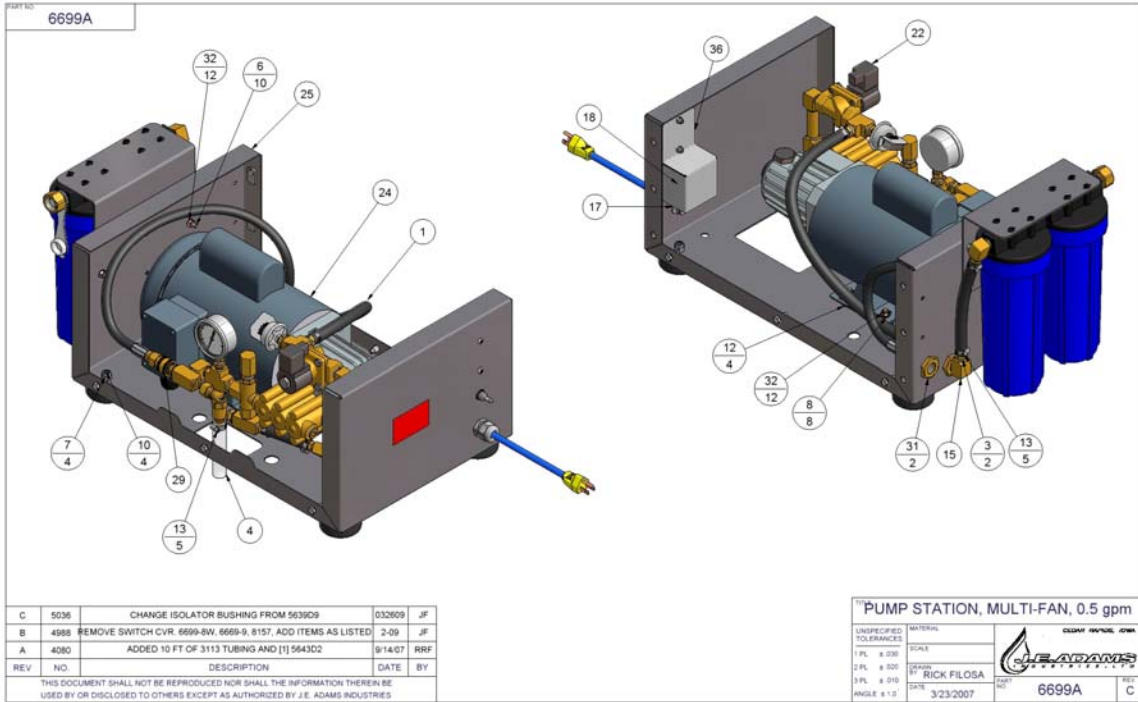

Use "6699KIT" for wall hanging fan hookup.

